

CITYBAC[®]

1100L LID-IN-LID



RESOPRE

| SOLUÇÕES
URBANAS

Citybac 1100L

Características



- | | |
|----------------------------|-------------------------------------|
| 1 Tampa plana | A Corpo reforçado |
| 2 Pega frontal | B Sistema de elevação DIN |
| 3 Pegas laterais 2x | C Nervura para empilhamento |
| 4 Dobradiça com apertos 2x | D Zonas de marcação /Personalização |
| 5 Zonas de personalização | E Pegas laterais ergonómicas x4 |
| | F Alojamento para chip |
| | G DINS |
| | H Rodas funcionais x2 |
| | I Travões em duas das rodas x2 |
| | J Rodas x2 |

CERTIFICAÇÕES



RESOPRE

| SOLUÇÕES
URBANAS

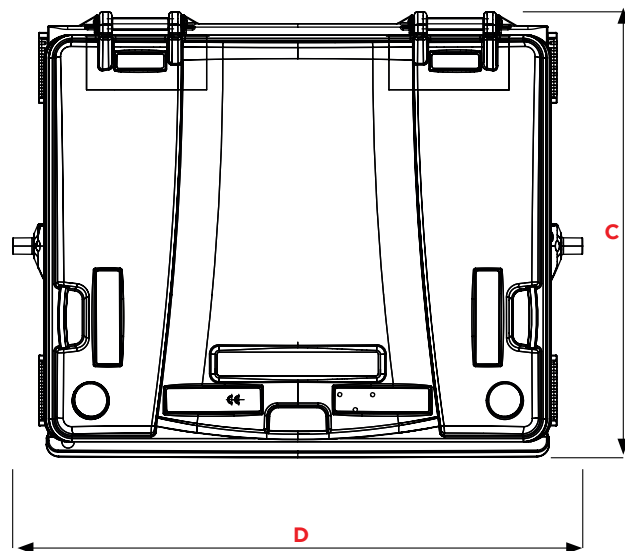
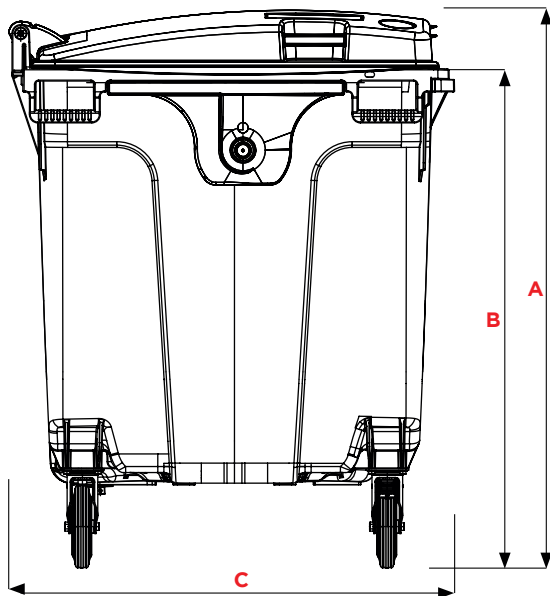

TAMPA PLANA

Dimensões (mm)

A Altura ~	1330
B Altura do Pente~	1205
C Profundidade ~	1075
D Largura~	1370

Pesos

Volume (L)	1100
Peso vazio(kg) ~	46
Max. peso cheio (kg) ~	440
Max. peso total (kg) ~	510



TAMPA PLANA "LID IN LID"

Dimensões (mm)

A Altura ~	1330
B Altura do Pente~	1205
C Profundidade ~	1075
D Largura~	1370

Pesos

Volume (L)	1100
Peso vazio(kg) ~	46
Max. peso cheio (kg) ~	440
Max. peso total (kg) ~	510

Citybac[®] 1100L

CARACTERÍSTICAS

CORES



CINZENTO
RAL 7021
AT



Os corpos dos contentores são constituídos por polietileno de alta densidade com proteção UV. Estes têm incorporado 100% de matéria reciclada, sendo totalmente recicláveis.

Combinação perfeita junto com tampas coloridas para a identificação da fração



CINZENTO
RAL 7021
AT



VERDE
RAL 6011
VJ



CASTANHO
RAL 8025
MR



AZUL
RAL 5023
BN



AMARELO
RAL 1018
JA



LARANJA
RAL 2008
OF



VERMELHO
RAL 3000
RN

MAIS OPÇÕES ECO CIRCULAR PARA O CORPO



VERDE
RAL 6011
VJ



CASTANHO
RAL 8025
MR



AZUL
RAL 5023
BN



AMARELO
RAL 1018
JA



As cores verde, castanho e azul podem incorporar até 100% de material reciclado.

Outras cores e combinações disponíveis mediante pedido mínimo. As tonalidades podem variar devido à produção. Os RALS indicados são meramente indicativos.

RESOPRE

| SOLUÇÕES
URBANAS

SOBRETAMPAS



Sobretampa Lid-in-Lid
Cores disponíveis



Sobretampa curta
Cores disponíveis



BOCAS DE DEPÓSITO

VIDRO



Boca circular com obturador
Ø 150 mm

PAPEL

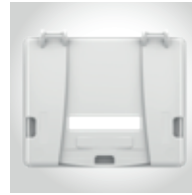

Boca de 530 x 95 mm

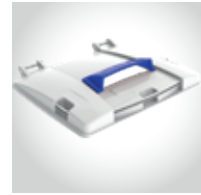

Abertura para papel AZUL

*Sob-consulta possibilidade de boca circular com ou sem obturador.

SISTEMAS DE ELEVAÇÃO



Sistema de viragem para carrinhos de mão



DIN



Asas laterais x2

ASAS

TRANSPORTE



Peça para reboque

ABERTURA



Pedal

INSONORIZAÇÃO



Insonorização



Amortecedor trava na tampa

RODAS



Jante de plástico
Roda de borracha
Ø 200 mm



Jante de plástico
Roda de borracha
Ø 200 mm,
sem pegadas



Jante de aço
Roda de borracha
Ø 200 mm



Travão (DS)



Travão central (ZF)



Travão de bloqueio direccional

SISTEMA DE BLOQUEIO



Fechadura



Cadeado



Fechadura automático

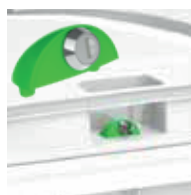

Fechadura manual

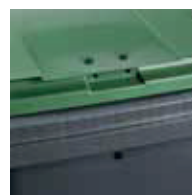

Fechadura gravítica

Citybac 4-rodas

INFORMAÇÃO TÉCNICA

1000 L

SISTEMA DE ESVAZIAMENTO

Pressão DIN

TAMPA

Standard

Curva

BOCAS DE DEPÓSITO

Abertura papel

Abertura papel XXL

Boca circular com obturador Ø 150 mm

Sobretampa curta / Lid-in-Lid

LID IN LID

Clip

INSONORIZAÇÃO

Borrachas amortecedoras

Sistema de redução de ruído na abertura da tampa

SISTEMA DE BLOQUEIO

Fechadura manual Fechadura automática Fechadura gravítica

SISTEMA DE ELEVAÇÃO

Frontal

Oschener

DIN

RODAS

Rodas standard ø 160

Rodas standard ø 200

12km/h rodas reforçadas ø 160

12km/h rodas reforçadas ø 200

1100 L

ACESSÓRIOS

Pedal	■
Poste de fixação	
Reforço do anel superior	
Reforço inferior	
Peça para reboque	■

SISTEMA DE DRENAGEM

Bujão de drenagem	■
-------------------	---

ANTI-ODOR

Anti odor

PERSONALIZAÇÃO

Fotoinjecção na tampa	
Autocolante	■
Pavé em relevo	
Termogravação / serigrafia	■

IDENTIFICAÇÃO

RFID Chip	■
Numeração	■

- Standard
- Opcional



RESOPRE

resopre.pt